

# DAWN VERTICAL HANDLE, HOLDING DOWN ACTION TOGGLE CLAMPS

The 'U' shaped work holding bar allows lateral adjustment of hold-down spindle (refer accessories) along the holding bar or multiple clamping of work pieces. A bolt retainer (refer accessories) can be welded on to the solid holding bar at any angle to compensate for angular contact. 'T' handles are shorter and suitable for restricted space conditions. The handles are fitted with plastic safety grip.

Part No.	Model	Type	Holding Capacity	Weight	A	B	C	D	E	F	G	H	J Diam.	K	Spindle Size
61251	SU-107-25	Vertical straight handle, U-bar	400 kg	0.5 kg	206	113	36	32	44	51	62	62	8	37	
61252	SU-107-35		375 kg	0.6 kg	225	138	55	32	44	51	62	87	8	63	
61253	SU-107-50		350 kg	0.7 kg	246	176	75	32	44	51	62	125	8	100	
61700	SU-105-40		280 kg	0.6 kg	195	141	42	32	45	48	65	93	8	61	
61745	SU-107-15		110 kg	0.2 kg	98	70	23	13	27	26	39	43	5	24	M6
61748	SU-107-20		170 kg	0.4 kg	143	91	32	19	35	32	45	56	6.5	33	M8
61749	SU-107-20L	170 kg	0.5 kg	143	127	32	19	35	32	45	95	6.5	76	M8	
61256	SS-107-25	Vertical straight handle, Solid bar	400 kg	0.5 kg	206	113	36	30	44	51	62	62	8	-	
61257	SS-107-35		375 kg	0.6 kg	225	138	55	30	44	51	62	87	8	-	
61258	SS-107-50		350 kg	0.7 kg	246	176	75	30	44	51	62	125	8	-	
61259	SS-104		545 kg	2.5 kg	345	276	110	50	73	76	100	200	11	-	
61754	SS-107-20L		220 kg	0.5 kg	143	119	32	19	35	32	45	87	6.5		
61262	TU-107-25	Vertical T handle, U-bar	400 kg	0.5 kg	153	113	36	32	44	51	62	62	8	37	
61263	TU-107-35		375 kg	0.6 kg	172	138	55	32	44	51	62	87	8	63	
61264	TU-107-50		350 kg	0.7 kg	193	176	75	32	44	51	62	125	8	100	
61267	TS-107-25	Vertical T handle, Solid bar	400 kg	0.5 kg	153	113	36	32	44	51	62	62	8	37	
61268	TS-107-35		375 kg	0.6 kg	172	138	55	32	44	51	62	87	8	63	
61269	TS-107-50		350kg	0.7kg	193	176	75	32	44	51	62	125	8	100	

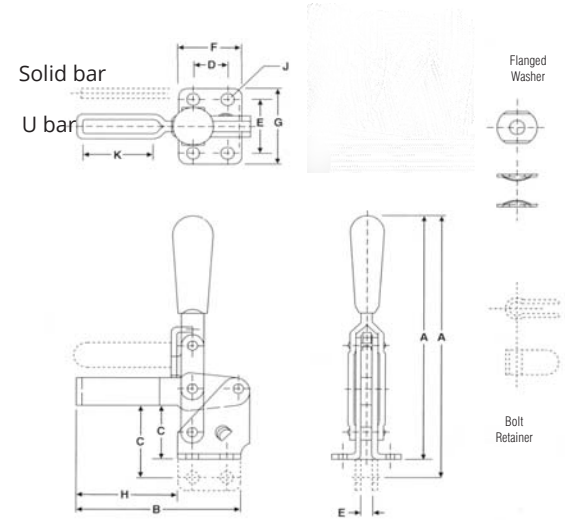

Vertical Handle U Bar



Vertical Handle Solid Bar



T Handle U Bar

